

## 2002-07 GENINFO

## Charging - Overview - MINI

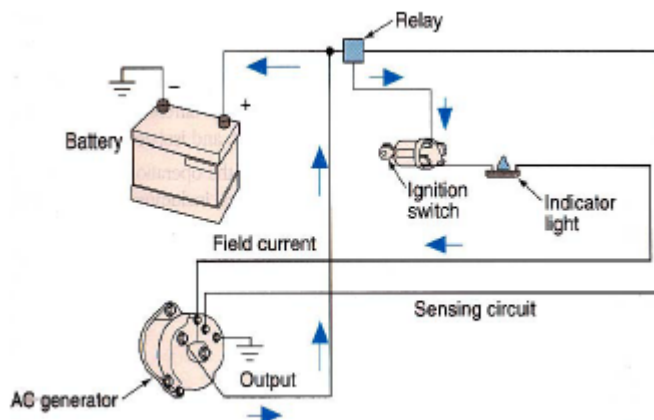
**MINI CHARGING SYSTEM****MINI CHARGING SYSTEM****Purpose of the Charging System**

The purpose of the charging system is to convert the mechanical energy of the engine into electrical energy that is used to recharge the battery and power the electrical accessories. When the engine is first started, the battery (s) supplies all the current required by the starting and ignition systems.

As the battery drain continues and engine speed increases the charging system is able to produce more voltage than the battery can deliver. When this occurs, the electrons from the charging device are able to flow in a reverse direction through the battery's positive terminal. The charging device now supplies the electrical system's load requirements and recharges the battery.

The charging system consists of:

- Battery
- Generator
- Drive Belt
- Rectifier Assembly
- Voltage Regulator
- Charge Indicator
- Ignition Switch
- Cables and Wiring Harness



**Fig. 1: Charging System Components**

Courtesy of BMW OF NORTH AMERICA, INC.

## System Components

### Battery

The Battery is the primary EMF source in the automobile. The automotive battery is an electro-mechanical device that provides the potential difference (voltage). The battery does not store electrical energy. It stores chemical energy that is converted to electrical energy as it discharges.

### Generator

The Generator produces free electrons necessary to charge the battery. The electron flow is produced through inductance, a magnetized rotor spinning inside a stator. The generator produces AC voltage which is converted to DC voltage or rectified.

The MINI uses an air cooled Brush Type generator.

**NOTE: In an attempt to standardize terminology in the industry, the term alternator is being replaced with generator. Often an alternator is referred to as an AC generator.**

The Brush Type generator consists of the following main components:

- Generator Housing
- Stator Assembly
- Rotor Assembly

### Generator Housing

The Housing is made of two pieces of die-cast aluminum. Aluminum is used because it is non-magnetic, light weight and provides good heat dissipation.

Bearings for support of the rotor assembly are mounted in the front and rear housings.

### Stator Assembly

The Stator is fixed to the housing of the generator and does not turn. It contains three main sets of windings wrapped in slots around a laminated, circular iron frame. Each of the three windings has the same number of coils as the rotor has pairs of north and south poles. The coils of each winding are evenly spaced around the core.

The three sets of windings alternate and overlap as they pass through the core in order to produce the required phase angles.

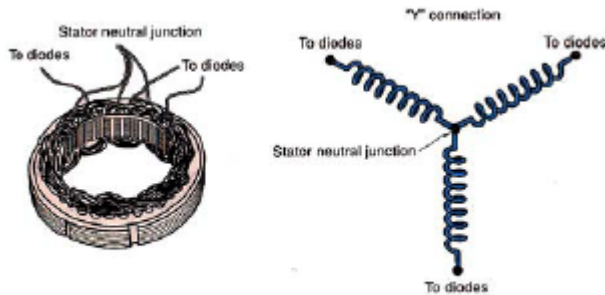
Each group of windings occupy one third of the stator, or 120 degrees of the circle.

The voltage produced by each loop of the stator is at a different phase angle, as a result the output of the stator is divided into three phases.

Two common methods of connecting the windings are:

- Y Connection
- Delta Connection

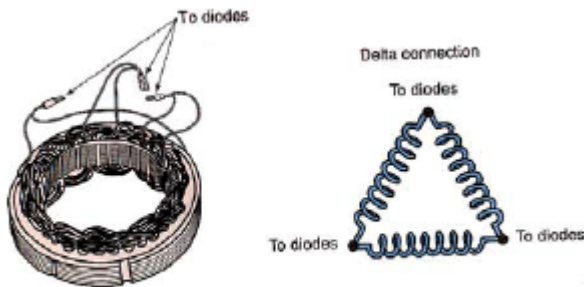
The parallel path of the Delta connection makes more current available.



**Y Connection**

**Fig. 2: Y Connection Diagram**

Courtesy of BMW OF NORTH AMERICA, INC.



**Delta Connection**

**Fig. 3: Delta Connection Diagram**

Courtesy of BMW OF NORTH AMERICA, INC.

**Rotor Assembly**

The Rotor Assembly consists of the rotor shaft, a winding around an iron core, two pole pieces and slip rings.

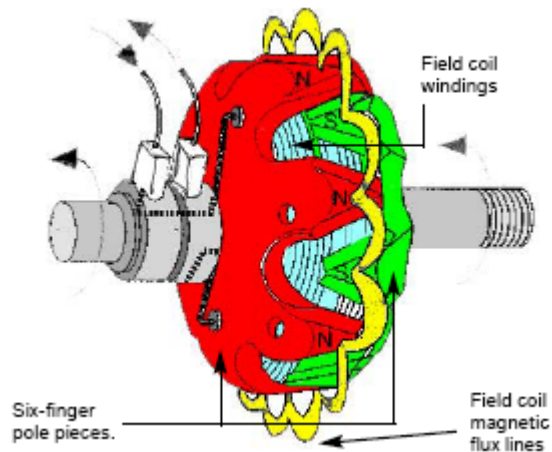
The rotor shaft is pressed into the core, then six-fingered malleable iron pole pieces are assembled on the shaft against each end of the winding core.

The pole pieces are placed so that the fingers mesh but do not touch. When direct current is passed through the field coil winding, the fingers become alternately North and South poles.

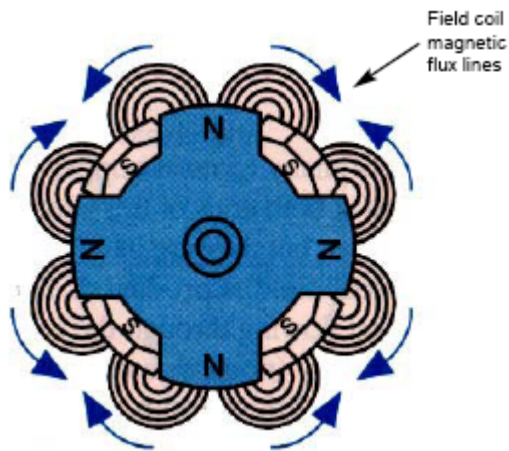
As a result of this arrangement of poles, the magnetic flux lines will move in opposite directions between adjacent poles.

**NOTE:** Flux lines always move from North to South.

This arrangement provides for several alternating magnetic fields to intersect the stator as the rotor is turning.

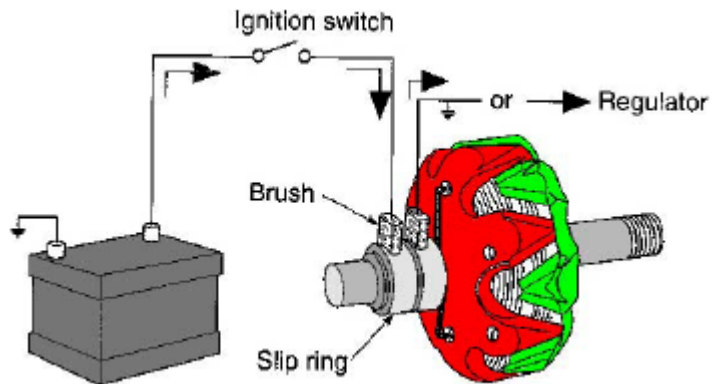


**Fig. 4: Field Coil Windings And Six-Fingerpole Pieces**  
Courtesy of BMW OF NORTH AMERICA, INC.



**Fig. 5: Field Coil Magnetic Flux Lines**  
Courtesy of BMW OF NORTH AMERICA, INC.

A slip ring pressed on to the rotor shaft is connected to the two ends of the field winding. Two brushes are held by springs against the slip rings. One brush is connected through a switch to the battery B+, the other to the voltage regulator. The brushes conduct only the field current (2 to 5 amps).



**Fig. 6: Rotor Function Diagram**

Courtesy of BMW OF NORTH AMERICA, INC.

#### Drive Belt

It is the function of the Drive Belt to transfer rotating energy from the engine to the generator. The drive belt rotates the rotor, spinning the magnetic field. A loose belt can inhibit charging system efficiency and a belt that too tight causes early bearing failure.

#### Rectifier Assembly

The Rectifier Assembly consists of six diodes, a pair of diodes for each stator winding.

Each pair contain one positive biased diode and one negative biased diode. By using a pair of diodes that are reversed biased to each other, rectification of both sides of the AC sine wave is achieved. The negative biased diodes allow for conducting current from the negative side of the AC sine wave and putting this current into the circuit as positive current.

The use of positive and negative biased diodes provide for full wave rectification because both halves of the sine wave are used.

#### Voltage Regulator - Multifunction Controller

The electronic regulator prevents excessively high voltage output of the generator. Excessive voltage would cause damage to the battery (through overcharging), light bulbs, motors, and particularly sensitive electronic components.

The voltage regulators is mounted internally towards the back of the generator assembly. It prevents damage to components by varying the amount of time the field coil is energized. The duty cycle of the field coil ground side is varied based on the demand placed on the electrical system.

The electronic voltage regulator compares field current supply voltage (from the stator windings through the diode trio) against a set voltage level (using a zener diode).

As the field current supply voltage surpasses the zener diode's breakdown voltage, the field current to the rotor is switched off. When the field current voltage to the rotor is off, the generator is not producing voltage. A rapid



### Ignition Switch

The Ignition Switch provides initial power for the field circuit of the alternator, reducing the time required for the field to develop the magnetic field. Depending on which type of regulator is employed the ignition switch supplies power to the charge indicator to check bulb integrity.

### Cables and Wiring Harness

The Cables and Wiring Harness are used to deliver the voltage produced by the generator to the battery for storage, and to vehicle systems to supplement battery voltage.

### Charging System Principles of Operation

Charging Systems use the principle of electromagnetic induction to generate electrical power. Electromagnetic induction occurs in a generator when a magnetic field is rotated within a stationary conductor. The magnetic field can be generated by permanent magnets or as in the case of the automotive generator by powerful electromagnets.

Passing electric current through a wire or winding causes a magnet field to surround the wire or winding. The number of turns in the winding and the magnitude of the current flowing through the winding determine the magnetic field strength.

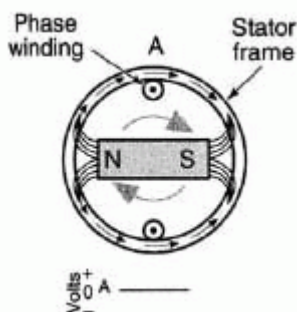
The strength of the field is further increased by surrounding the coil with pole pieces. The poles will take on the polarity (North or South) of the side of the coil they touch or the ones they are closest to. The combined windings (field coil) and pole pieces are referred to as the rotor. Output of the generator is regulated through control of field coil intensity.

An examination of single phase AC voltage generation, will aid in the understanding of 3 phase AC voltage generation.

### Notes:

#### Single-Phase AC Voltage Generation

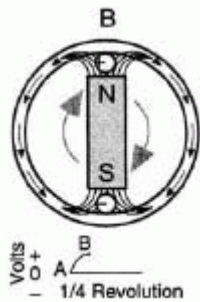
Single Phase AC Voltage Generation requires one stator frame with windings and one magnetic field (North and South pole pieces).



**Fig. 8: Single-Phase AC Voltage Generation - Condition A**

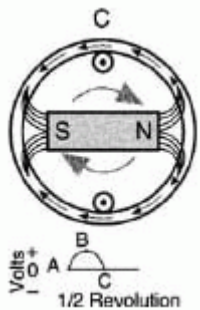
**Courtesy of BMW OF NORTH AMERICA, INC.**

As the North pole of the rotor pole piece approaches the winding of the stator, induced voltage level in the stator begins to rise. The closer the North pole gets to the stator winding the higher the induced voltage. As the North pole reaches  $90^\circ$  to the stator winding the maximum amount of flux lines are acting on the winding, induced voltage is at its highest positive value (1/4 turn).



**Fig. 9: Single-Phase AC Voltage Generation - Condition B**  
**Courtesy of BMW OF NORTH AMERICA, INC.**

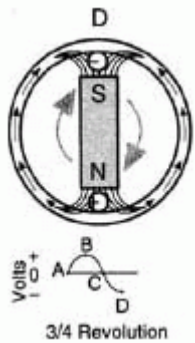
The rotor continues to rotate and the North pole gets further away from the winding. The voltage drops, until 0 voltage is induced through the stator (1/2 turn).



**Fig. 10: Single-Phase AC Voltage Generation - Condition C**  
**Courtesy of BMW OF NORTH AMERICA, INC.**

With the South pole now approaching the winding voltage begins to increase negatively. When the South pole reaches  $90^\circ$  to the winding, again the maximum amount of flux lines are acting on the winding and induced voltage is at its greatest negative value (3/4 turn).

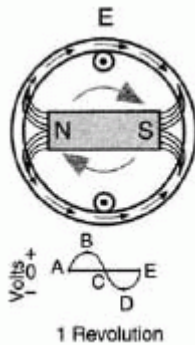




**Fig. 11: Single-Phase AC Voltage Generation - Condition D**  
 Courtesy of BMW OF NORTH AMERICA, INC.

The South pole continues to travel farther away from the winding decreasing the negative voltage value until 0 voltage is again reached (1 full turn).

This comprises one cycle or 360° rotation of the magnetic field.

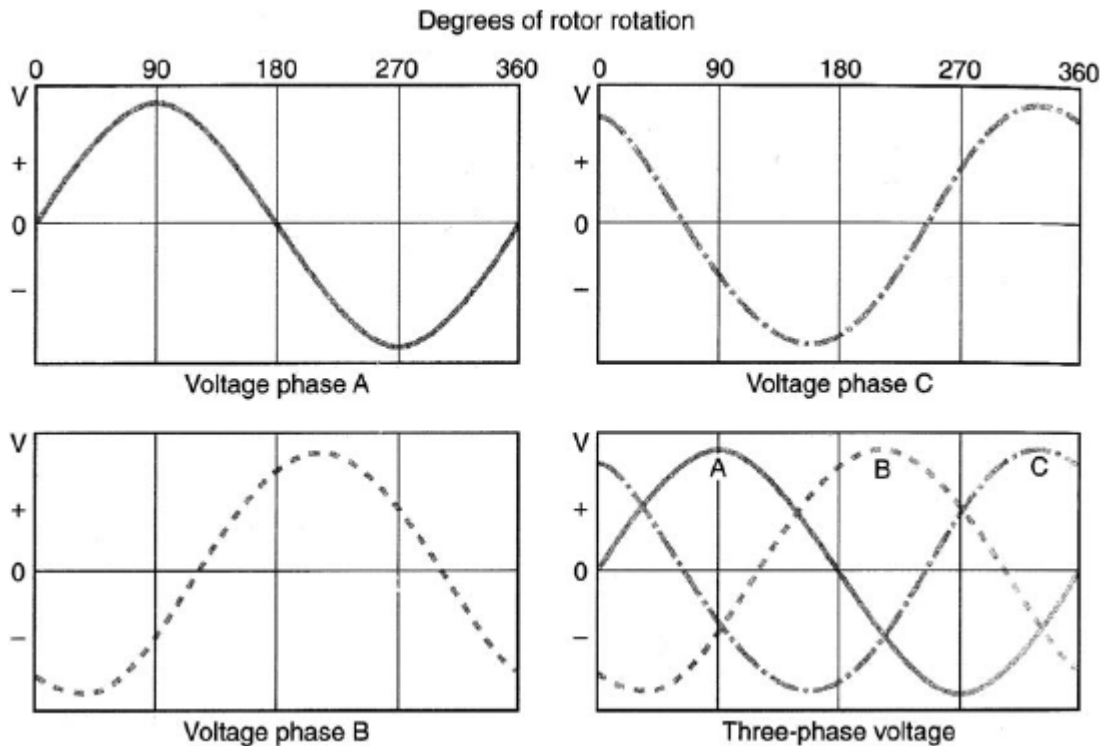


**Fig. 12: Single-Phase AC Voltage Generation - Condition E**  
 Courtesy of BMW OF NORTH AMERICA, INC.

Sine wave produced by a single winding of the stator during a single revolution of one pair of pole pieces is called single phase voltage.

**Three-Phase AC Voltage Generation**

Most AC generators use either a twelve or a fourteen pole rotor. Each pair of poles (North and South) produce one complete sine wave in each winding per revolution.



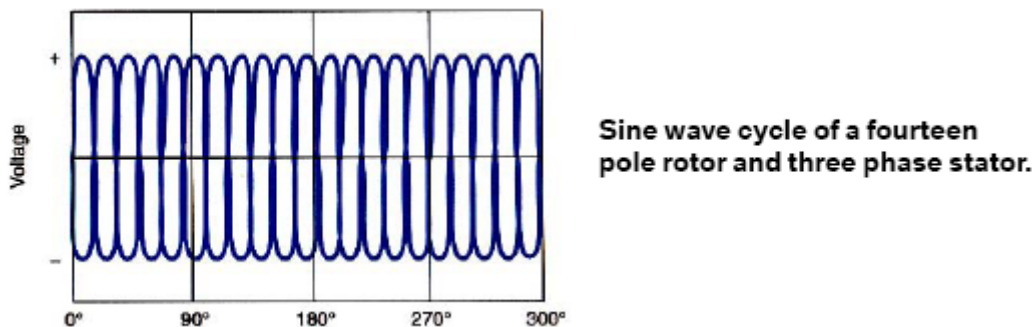
**Fig. 13: Three-Phase Voltage Stator Winding**  
 Courtesy of BMW OF NORTH AMERICA, INC.

Voltage of each stator winding is added together to create three-phase voltage.

During one revolution a fourteen pole rotor will produce seven sine waves. (The stator has one winding (coil) for each pair of rotors.)

The rotor generates three overlapping sine wave voltage cycles in the stator (one rotor three sets of windings in the stator).

The total output would be twenty one sine wave cycles per revolution. (3 sets of stator windings, each with 7 coils).



**Fig. 14: Sine Wave Cycle Of Fourteen Pole Rotor and Three Phase Stator**

Courtesy of BMW OF NORTH AMERICA, INC.

### Sine wave cycle of a fourteen pole rotor and three phase stator.

#### Voltage Rectification

The battery and the electrical system cannot store or use the 3-phase AC voltage produced by a generator, it must be rectified or converted to DC voltage.

A diode rectifier bridge is used to make the conversion.

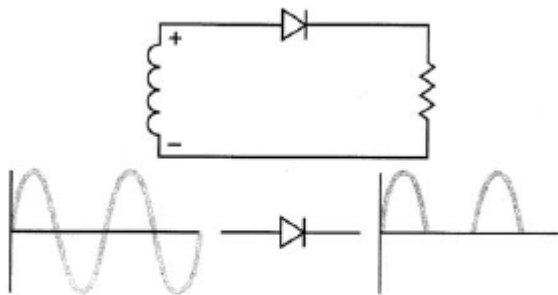
The diode is similar to a non-return or one way valve which permits the passage of a fluid or gas in only one direction.

In a simple conversion the rectifier diode suppresses the negative half waves and allows only positive half waves to pass.

To make use of the negative value half waves full rectification is applied.

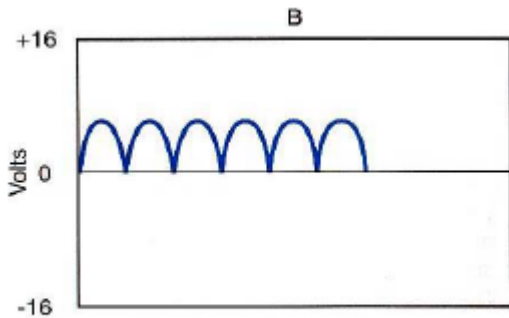
Full rectification of the negative half waves invert them into positive half waves.

The result is a rectified pulsating direct current.



**Rectified Pulsating DC current**

**Fig. 15: Rectified Pulsating DC Current**  
Courtesy of BMW OF NORTH AMERICA, INC.



**Rectified Pulsating DC current**

**Fig. 16: Rectified Pulsating DC Current**  
 Courtesy of BMW OF NORTH AMERICA, INC.

**Three-Phase Voltage Rectification**

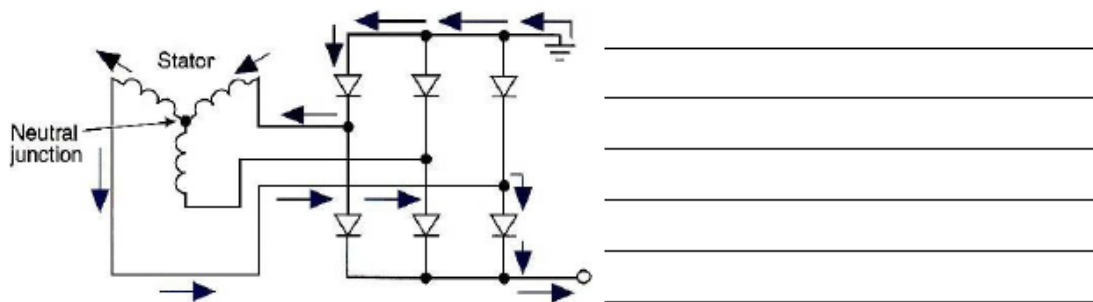
Six diodes are used to achieve three-phase AC voltage rectification. Three diodes are positive biased and three are negative biased.

The positive half-waves pass through the positive biased diodes and the negative half-waves through the negative biased diodes.

Diode rectification of the negative half-waves invert them into positive half-waves.

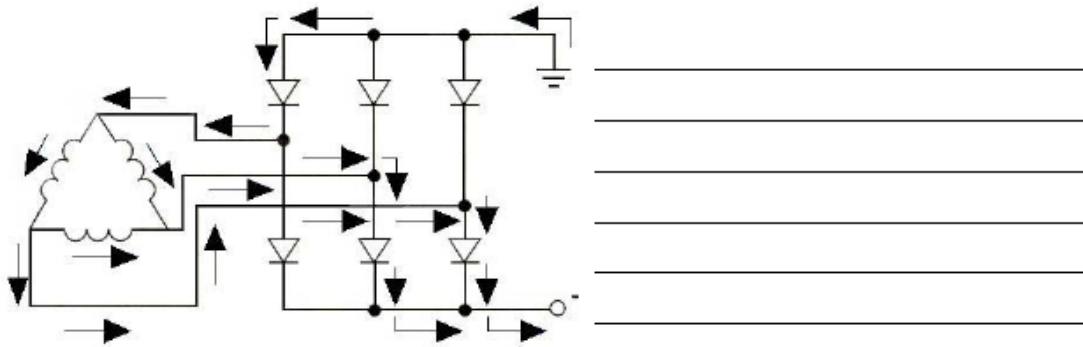
With full rectification DC voltage supplied to vehicle by generator is not ideally smooth, but exhibits a slight ripple. This ripple is further smoothed by the battery which is connected in parallel with the generator.

The rectifier diodes in the generator not only convert the current but also prevent battery discharging through the 3 phase windings of the stator. Current flow can only take place from the generator to the battery.



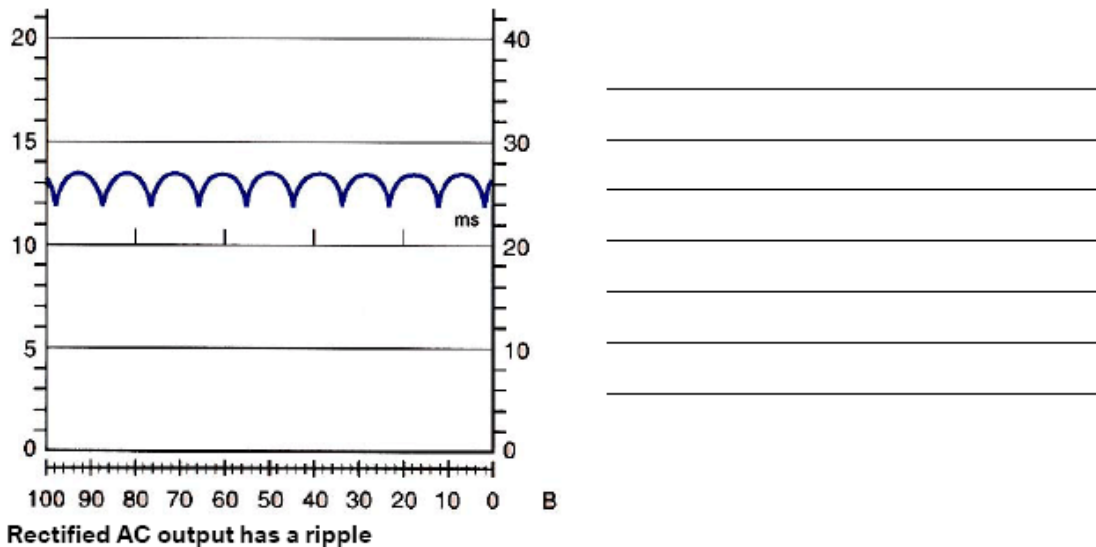
**Current flow through Y wound stator.**

**Fig. 17: Current Flow Diagram Through Y Wound Stator**  
 Courtesy of BMW OF NORTH AMERICA, INC.



Current flow through Delta wound stator

**Fig. 18: Current Flow Diagram Through Delta Wound Stator**  
 Courtesy of BMW OF NORTH AMERICA, INC.



**Fig. 19: Rectified AC Output Has Ripple**  
 Courtesy of BMW OF NORTH AMERICA, INC.

**Voltage Regulation**

The Electronic Regulator uses a zener diode that blocks current flow until a specified voltage is obtained.

Sensing current from terminal 2 passes through a thermistor to the zener diode (D2). As the system voltage exceeds the breakdown voltage of the zener diode, current flows through the zener diode turning transistor 2 (TR2) on.

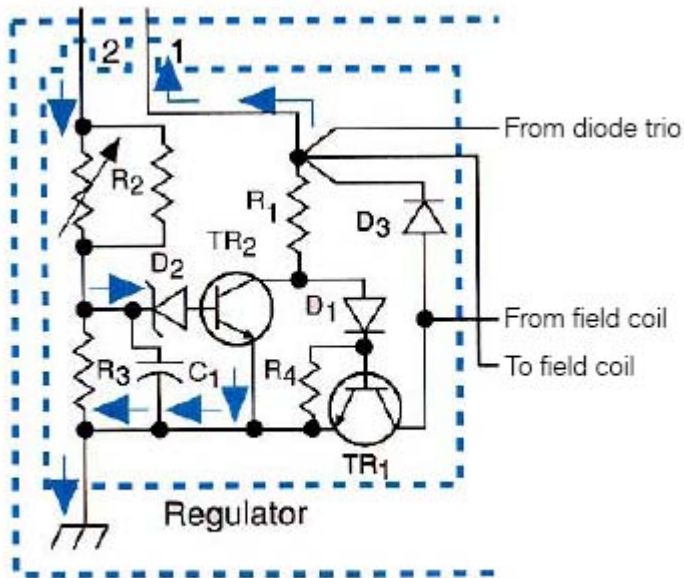
With TR2 on transistor 1 (TR1) is shut off.

Transistor 1 controls field current to the rotor.

With TR1 off no current flows to the field coil and the generator has no output.

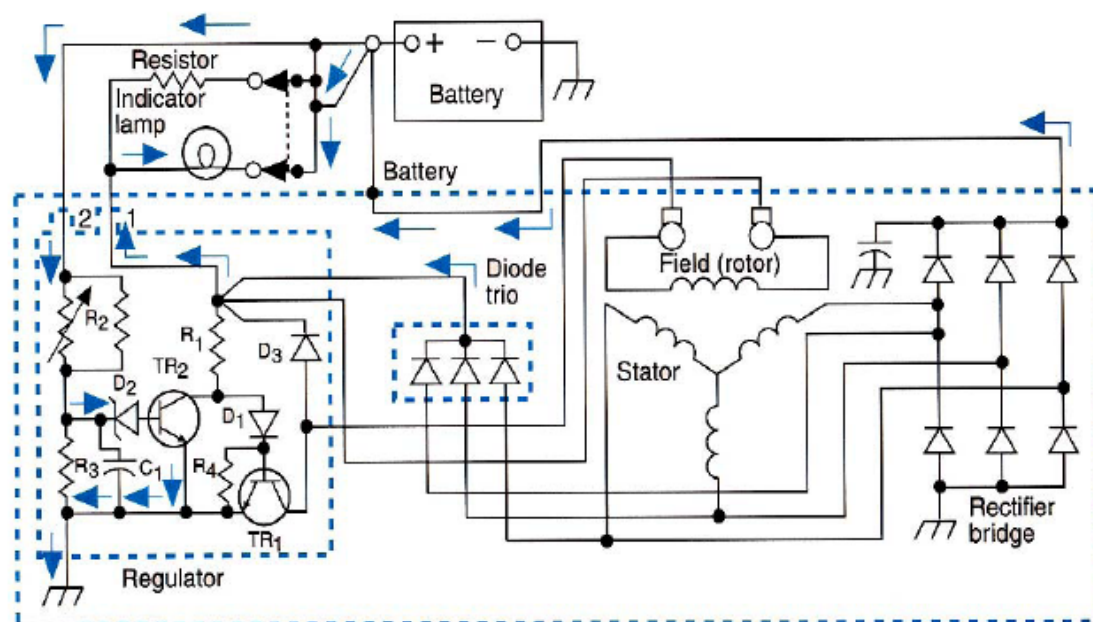
A voltage drop below the breakdown voltage of the zener diode stops the current flow to TR2 which turns on TR1.

Voltage is again applied to the field allowing the generator to produce voltage.



Expanded View of Voltage Regulator

**Fig. 20: Voltage Regulator Circuit Diagram**  
 Courtesy of BMW OF NORTH AMERICA, INC.



Voltage regulator with Field coil off, no charging

**Fig. 21: Voltage Regulator with Field Coil Off, No Charging Circuit Diagram**  
 Courtesy of BMW OF NORTH AMERICA, INC.

### Charge Indicator System

The Charging System Indicator light operates on the principle of opposing voltage. Battery voltage is supplied to one side of the light bulb, the other side of the bulb is connected to the voltage regulator.

With the key turned on, power is sent to the light bulb, through to the regulator. No voltage is being produced by the stator, so there is no voltage from the diode trio. This lack of voltage from the diode trio, allows the voltage from the ignition switch to flow through the regulator to ground. This completes the circuit allowing current to allow the charge indicator bulb to illuminate.

As the generator begins to produce voltage, the output of the diode trio equals battery voltage. This equal voltage is supplied to the light bulb. With equal voltage on each side of the light bulb, no current can flow and the light is turned off.





generator.

Test plans available:

- Generator (Checks voltage and current output)
- Wiring from generator to battery (Performs voltage drop test)
- Charge indicator lamp (Condition of bulb, wiring and signal to bulb)
- ON delay and Start ON delay (If applicable)
- Ground side circuit wiring (Voltage drop test)

Sub-tests may be available with some of the component testing.

There are many advantages to using the test plan.

1. Complete system testing.
2. Functional description of system on screen.
3. Proper wiring diagrams provided during testing.
4. Test instructions and notes.
5. Instructions for proper test set-up.
6. Display of nominal values.
7. Solutions.

#### Testing Generator using Measurement System

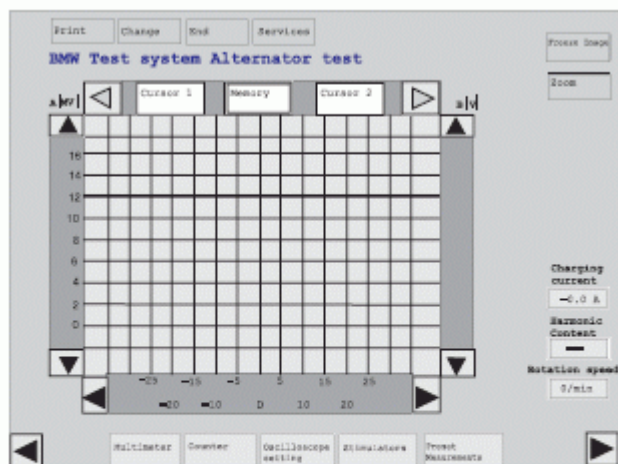
Enter the measurement system and select **Preset Measurements**.

Instruction on the proper hook-ups required are available through the HELP button, selecting **Help using Preset Measurement**.

The oscilloscope will display preconfigured for the testing.

Diagnostic information available through oscilloscope.

- Voltage Graph.
- Charging Current.
- Harmonic Content.
- Rotation Speed (Engine RPM).



## Workshop Hints

**Fig. 23: Diagnostic Information Oscilloscope Display**  
 Courtesy of BMW OF NORTH AMERICA, INC.

### Workshop Hints

- Harmonic Content - This is an expression of AC voltage contained in DC voltage. The higher the percentage of harmonic content the larger the amount of residual AC voltage in the DC voltage.

High residual AC voltage is caused by weak or failing diodes in the generator.

Generators which have harmonic content readings higher than specified (In TIS) should be replaced.

- Before beginning diagnostic procedures on the charging system do the following:

Run engine at idle speed for about 5 minutes

Switch off all electrical loads

This is done to ensure the battery is charged to such a level that the generator will not be fully utilized and that loads required during starting (e.g. starter, secondary air pump) will be already switched off.